

TECHNICAL SHEET 05.04.05-EN



JUBIZOL Anchor PPV

Screw-in fixing

1. Description, Application

JUBIZOL Anchor PPV are used for fixing JUBIZOL thermal insulations for facade systems, where it is necessary to prevent thermal bridges. This is done by sinking the anchor head into the insulation. The advantage of this anchor is that in order to sink the anchor head into the insulation, it is not necessary to drill the insulation with a scraper to sink the anchor head into the insulation, but this is done simultaneously with the installation of the anchor using the JUBIZOL crown for the installation of PPV anchors.

Features:

- high-quality screw fastener,
- high resistance of fasteners to UV rays,
- installing the anchor without prior milling of the insulation to retract the head of the fastener into the insulation using the PPV tool,
- simple and quick installation,
- to prevent thermal bridges (0.00 W/K),
- to level the surface of the insulation,
- possible use with pressure plates, which increase the mounting surface.

Additional accessories for installation:

- EPS W COVER PLUG
- EPS G COVER PLUG
- MW COVER PLUG
- PPV ANCHOR ASSEMBLY TOOL
- JUBIZOL PRESSURE PLATE

JUBIZOL Anchor PPV consists of two parts:

- a plastic insert with a cap,
- TORX screws.

2. Method of packing

In cartons (200 pieces from length 120 to 360, 100 pieces from length 380 to 500).

3. Technical data

Method of anchoring	Surface or deep anchoring
Anchor diameter	8 mm
Head diameter	60 mm
Anchorage depth hef	50 mm
Drill hole depth h1	20 mm
Point thermal transmission λ	0 W/K
Use categories	A, B, C, E
Technical approval	ETA - 12/0331

4. Product information

Fastener designation (length in mm)	Surface anchoring suitable for insulation board (thickness mm)	Borehole diameter (mm)
PPV 120	60 - 70	8
PPV 140	80 - 90	8
PPV 160	100 - 110	8
PPV 180	120 - 130	8
PPV 200	140 - 150	8
PPV 220	160 - 170	8
PPV 240	180 - 190	8
PPV 260	200 - 210	8
PPV 280	220 - 230	8
PPV 300	240 - 250	8
PPV 320	260 - 270	8
PPV 340	280 - 290	8
PPV 360	300 - 310	8
PPV 380	320 - 330	8
PPV 400	340 - 350	8
PPV 420	360 - 370	8
PPV 440	380 - 390	8
PPV 460	400 - 410	8
PPV 480	420 - 430	8
PPV 500	440 - 450	8
Consumption (piece/m²)	According to the calculation - JUBIZOL ENGINEERING	

5.1. Deep anchoring

JUBIZOL Anchor PPV can be used to fasten different types of insulation (EPS, MW, multipor, ...) to different substrates (concrete, brick, aerated concrete, ...). Information for determining anchor length based on insulation thickness is given in table in Chapter 4.

Through the insulation board, a $\varnothing 8$ mm diameter hole is drilled into the anchor base. The hole must be at least deeper than the length of the anchor. This is necessary due to the installation of the anchor itself, so that the dust that remains in the bore can be pushed forward to make room for the screw, which penetrates the anchor part of the insert when screwing.

Push the plastic insert into the hole. The head of the insert rests on the insulation. Insert the screw into the plastic insert and tighten it with the installation tool. In this process, the screw is screwed into the plastic insert, while at the same time the cutting crown cuts the insulation around the anchor head, thus enabling compression of the insulation, which is created by embedding the head into the insulation.

When the stop disc on the installation tool rests against the insulation, the screwing stops. If it continues, deformation of the surface of the insulation occurs, resulting in unevenness on the surface.

The effective anchoring depth h_{ef} is always 50 mm. After the screwing is completed, a plug, a $\varnothing 70$ mm roundel, is inserted into the recessed part to level the recessed thermal insulation above the anchor head, while at the same time preventing the formation of a thermal bridge.

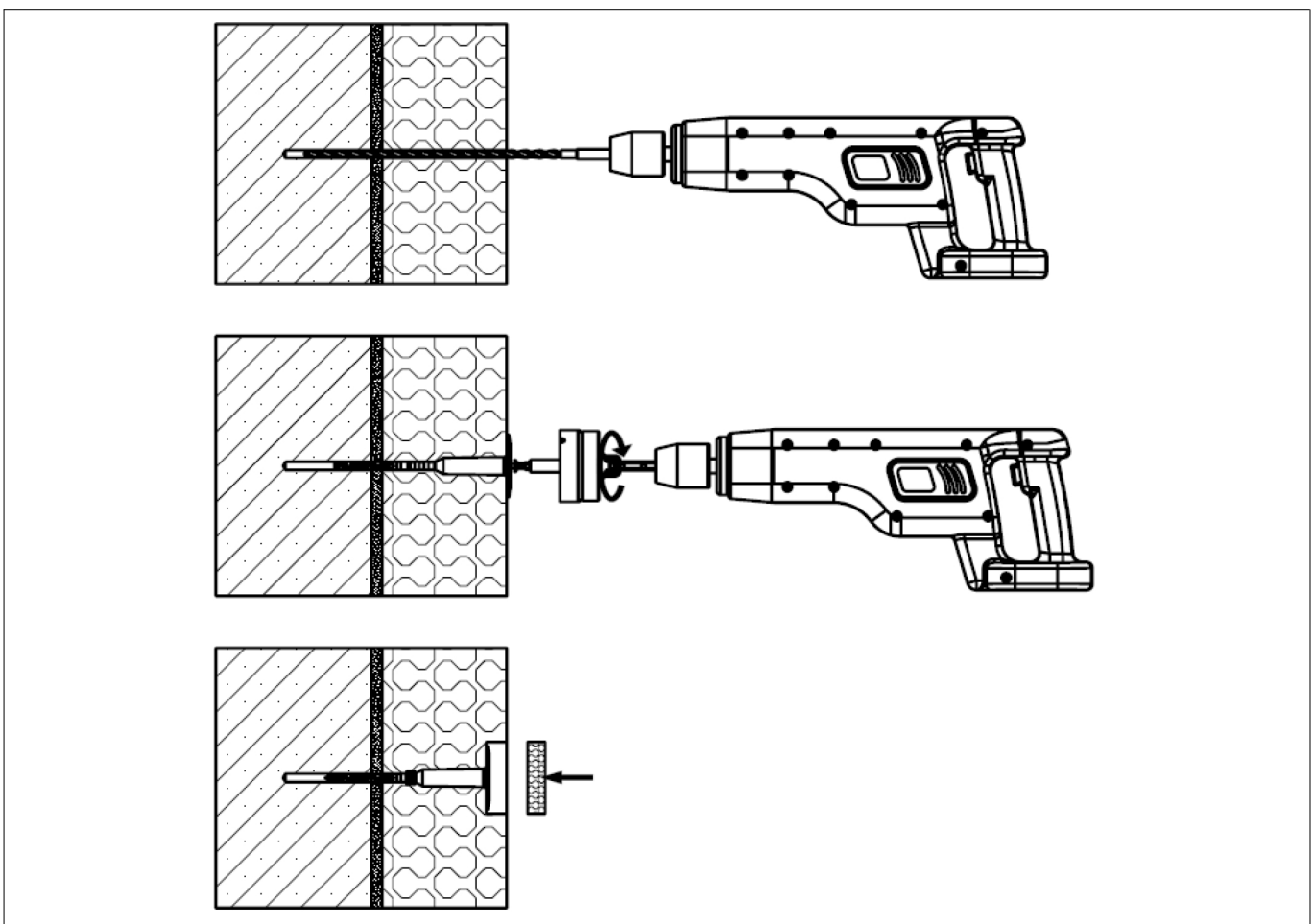

5.2. Surface anchoring

JUBIZOL Anchor PPV can be used to fasten different types of insulation (EPS, MW, multipor, ...) to different substrates (concrete, brick, aerated concrete, ...). Information for determining anchor length based on insulation thickness is given in table in Chapter 4.

Drill a $\varnothing 8$ hole through the insulation board into the anchor base. The hole must be at least deeper than the length of the anchor. This is necessary due to the installation of the anchor itself, so that the dust that remains in the bore can be pushed forward. Then push the plastic insert into the hole. The head of the insert rests on the insulation.

We insert a screw into the plastic insert and screw it in with a torx T25 bit, which is inserted into the screw

extension. In this process, the screw is screwed into the plastic insert until the head of the anchor is pressed tightly against the insulation.

If we continue screwing, the surface of the insulation will be deformed and, as a result, unevenness on the surface. The effective anchoring depth hef is always . After finishing the screwing, an EPS plug Ø14x20 mm can be inserted into the stem of the plastic insert, or polyurethane foam can be injected.

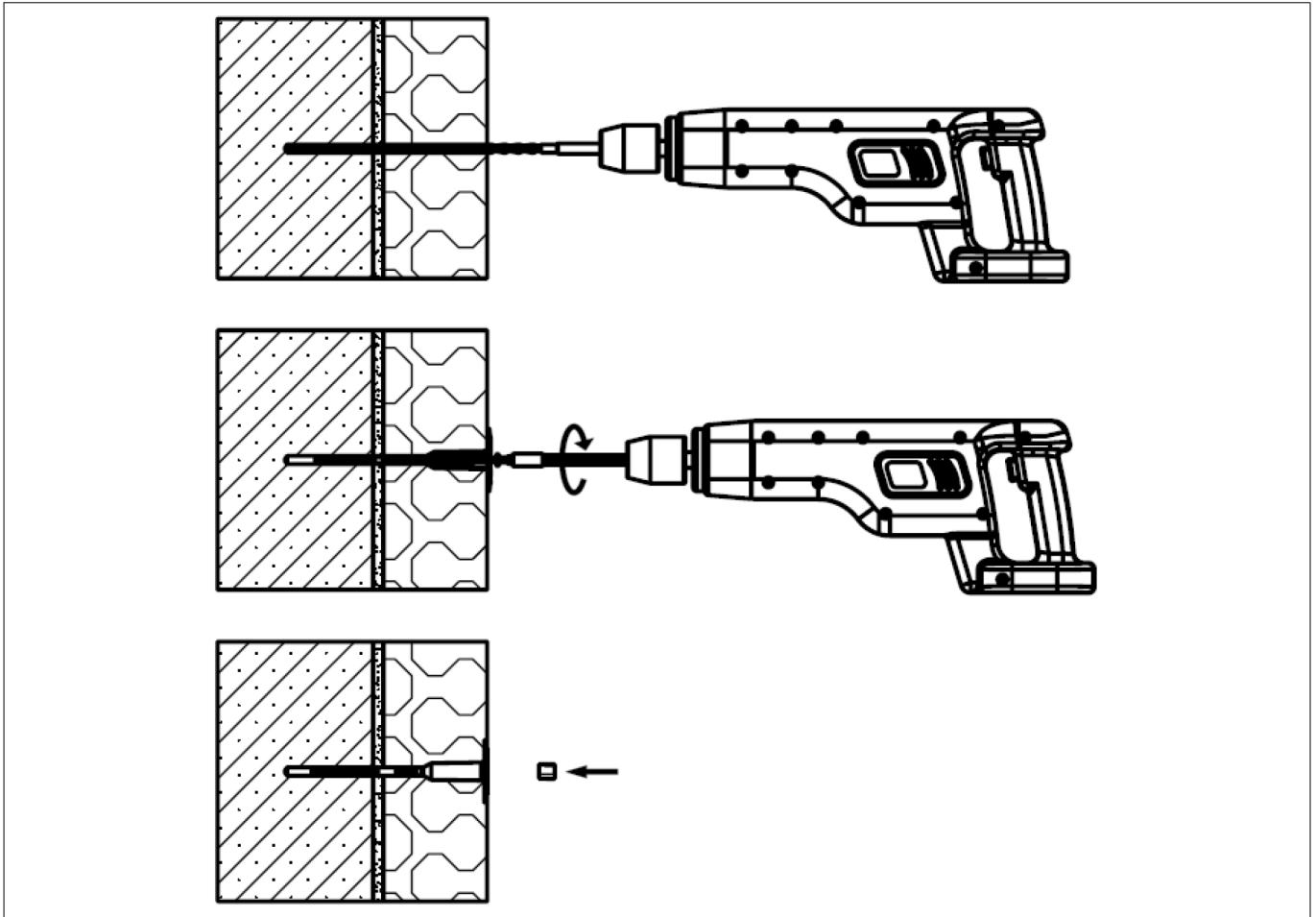

6. Instructions for safe use of the product

Further instructions regarding handling the product, use of personal protection equipment, waste management, first aid measures, warning signs, signal words, components determining hazard, hazard statements and safety statements are listed in the product's safety sheet which you can find on Jub's web page or you can require it from the manufacturer or seller. When applying the product, the instructions and regulations regarding safety for construction, façade and painting works should also be observed.

7. Storage and transportation conditions

Packed in cardboard boxes. Store in a dry and covered place at a temperature of + 5°C to + 40°C. They are transported in a horizontal position.

8. Other Information

Technical instructions in this brochure are given based on our experiences and are given as a guideline for achieving optimal results. All guarantees for the characteristics of the product (including the shade) apply only to the complete JUB system. We cannot take any responsibility for the damage, caused by incorrect selection of a product, incorrect use or unprofessional work.

Safety measures: Follow the instructions on the safety data sheet of the product.

This technical sheet supplements and replaces all preceding editions. We reserve the right to change and supplement data in the future.

Denomination and date of publishing: TDS 025/26-pek, 17.03.2026